



MVP·X User Manual



Version 1.02
4 MAR 2015

Revision History

Revision	Date	Changes	Name
Version 1.0	27 Oct 2014	Created manual	DO
Version 1.01	4 Mar 2015	Formatting Edits	JZ
Version 1.02	22 June 2015	Updating technical specifications	JZ

Table of Contents

General Description of the Instrument.....	2
Where Do I Start?	3
Shipping & Receiving	4
Receiving an Instrument.....	4
Returning an Instrument to the Factory.....	4
Using the Instrument.....	5
Pressure Ratings	5
Pre-Deployment Procedures.....	5
Post-Deployment Procedures	5
Maintaining the Instrument.....	6
Periodic Maintenance	6
Communications	7
Factory Default Settings.....	7
Interrupting the Monitor Command	7
Returning MVP-X to Factory Default Settings for Use with Rolls-Royce MVPs	7
Output Formats.....	8
Default Output Format.....	8
Support	9
Troubleshooting.....	9
Contact AML Oceanographic.....	11
Appendices	12
Commands	12
Communications Commands.....	12
Sampling Rate Commands	12
Output Format Commands.....	13
General Commands.....	14
Technical Specifications	15
Ordering Codes.....	18
Instrument Packages (sensors included)	18
Instruments (sensors not included).....	18
Sensors	18
Accessories	Error! Bookmark not defined.
Warranty	20
Technical Overview Drawings	21

General Description of the Instrument

The AML Oceanographic X•Series instruments and Xchange™ sensors are a major advancement in oceanographic instrumentation. Swappable and interchangeable sensor technologies dramatically improve the capabilities of ocean instrumentation in the following ways:

- Change the instrument sensor types while at sea within seconds, and without tools. To optimize the resolution and accuracy of sensor data, sensors can be swapped to change the measurement range. For example, a 6000 dBar P•Xchange pressure sensor can be swapped with a 500 dBar P•Xchange sensor, and the salt water C•Xchange conductivity sensor can be swapped for a fresh water C•Xchange conductivity sensor.
- Sensors from one instrument can be swapped to another to maintain mission-critical capabilities.
- Calibrated sensors can be sent from the factory to the instrument. The instrument is not pulled from service for calibration.
- Spare sensors ensure that an instrument can be immediately returned to service after sustaining damage.
- All calibration and traceability data resides within each Xchange™ sensor. Calibration data for all sensors is available from the instrument, and calibration certificates can be printed from AML Oceanographic's SeaCast software whenever the instrument is connected.
- Logged data is stamped with sensor traceability and instrument configuration data. Only Xchange™ sensors are sent for calibration, leaving the instrument working in the field.

MVP•X is an externally powered, multi-parameter instrument that allows you to change the instrument's sensor load, in the field and on-demand. The instrument outputs data in real-time, and is designed specifically for Brooke Ocean's Moving Vessel Profiler product family.

There are two configurations of the MVP•X. One is a CTD and the other is an SVPT. Both configurations offer one primary Xchange™ sensor port (C•Xchange™ or SV•Xchange™) and two secondary Xchange™ sensor ports (T•Xchange™ or P•Xchange™).

Each configuration is optimized for the highest data quality for its specific parameters.

- In the CTD configuration, C•Xchange™ and T•Xchange™ are located on the same face, in close proximity.
- In the SVPT configuration, SV•Xchange™ is located on its own face, in undisturbed flow.

See the Technical Overview Drawings section at the end of this manual for a rendering of both configurations.

With factory settings, MVP•X communicates via the RS-485 protocol, at 19200 baud, at a sampling rate of 25Hz.

Where Do I Start?

AML Oceanographic's X•Series instruments ship with several manuals on the USB stick:

- An instrument manual (this MVP•X manual) providing an overview on how to use and maintain the instrument;
- Xchange™ sensor manuals (C•Xchange, SV•Xchange, P•Xchange, and T•Xchange) providing overviews on how to install and maintain each of the Xchange™ sensors;

If you are configuring an instrument for field use or lab testing, begin with the SeaCast manual.

If you are performing instrument maintenance, begin with the instrument manual.

If you are planning to swap an Xchange™ sensor, read the Xchange™ manual corresponding to your sensors.

Shipping & Receiving

Receiving an Instrument

When receiving an instrument, perform the following steps to ensure the instrument will be ready for deployment when required:

- Inspect the shipping container, looking for signs of damage. Damage to the shipping container could indicate damage to the instrument inside.
- The shipping package should include all of the following items
 - MVP·X instrument
 - Blue sensor box which includes:
 - One primary sensor blanking plug
 - Two secondary sensor blanking plugs
 - USB stick with manuals and documentation
- Inspect for damage
 - Check the cable for slices or gouges
 - Check the connector sockets for corrosion, dirt, and salt deposits
 - Check the pressure case for dents and scrapes
 - Check the sensors for cracks or bends
- Ensure all the Xchange™ sensors are installed tightly. The blue locking sleeve should be tight, and sitting less than 1 mm from the instrument end cap.
- Connect the instrument to a computer with the data cable and perform a scan or monitor if using SeaCast.

Returning an Instrument to the Factory

- If shipping for repair or recalibration, obtain an RMA number from the service centre.
- Pack the instrument in its original shipping box to prevent damage during shipping.

An RMA number can be requested using the contact options given in the Support section of this manual.

Using the Instrument

Pressure Ratings

Pressure ratings are given for Xchange™ sensors and the entire instrument. **Deployments should never exceed the lower of these two pressure ratings.** For example, MVP•X instruments are rated to 6000m, but are limited by the depth rating of the installed P•Xchange™ sensor. It is desirable to optimize the accuracy of pressure measurements by using a P•Xchange™ sensor with a pressure range that closely matches the depth of the deployment. There are four available pressure ranges offered with the MVP•X: 500dBar, 1000dBar, 4000dBar, and 6000dBar.

Caution: Do not exceed the specified pressure ratings of the P•Xchange™ sensor. Overpressure can result in damage to the sensors and the instrument.

Pre-Deployment Procedures

- Upon Receipt
 - Use the Shipping and Receiving instructions to verify the condition of the instrument.
 - Verify that all sensor calibrations are valid for the duration of the deployment. If not, swap the Xchange™ sensors for sensors with valid calibrations or send the Xchange™ sensors to a service centre for recalibration.
 - Lightly lubricate the underwater connectors with 3M silicone spray or equivalent.
- Before leaving the jetty
 - If applicable, verify the P•Xchange™ pressure range is correct for the deployment.

Caution: Install blanking plugs in all unused sensor ports prior to deployment. Failure to install blanking plugs will result in damage to the connectors.



Primary Xchange™ mount blanking plug



Secondary Xchange™ mount blanking plug

Post-Deployment Procedures

- When the instrument is pulled from the water, it should be rinsed in fresh water.
- Dry the area around the connectors with a clean cloth or compressed air prior to disconnecting the plugs or cables. **Do not blow compressed air into the Pressure•Xchange™ sensor. Doing so may damage the sensitive pressure transducer diaphragm.**
- Remove the shorting plug or cable, and place the dummy plug in the connector to protect it.
- Dry the instrument and stow it securely.

Maintaining the Instrument

Periodic Maintenance

Periodic preventative maintenance will prolong the life of the instrument. The following steps are recommended:

- If the instrument is dirty or oily, allow it to soak in warm, soapy water before cleaning with a rag or soft brush. When finished, rinse with fresh water to remove any residual soap or dirt.
- Before each use:
 - Check for proper installation of all Xchange™ sensors.
 - Check for nicks and cuts on the cable.
- After each use:
 - Clean and rinse the instrument using fresh water.
 - Dry the instrument completely, and store it in a cool, dry place.
- Monthly:
 - Lightly lubricate the connector contacts with 3M silicone spray or equivalent. Avoid the use of grease. It can create internal pressure and push past the connector seals on the pins.
 - Lubricate the end cap retainer rings with silicone grease.
- Yearly:
 - Send the instrument or Xchange™ sensors to a service centre for diagnostics and re-calibration.

Communications

Factory Default Settings

MVP•X have the following settings:

- RS-485
- 19200 BAUD rate
- Data on power up
- Sampling rate of 25 Hz

Interrupting the Monitor Command

MVP•X are set to *not* check the RX line and to output data continuously on power up. To interrupt that data flow to, for example, alter the default factory settings, you must interrupt the monitor command by performing the following steps:

- Open a terminal emulation program such as HyperTerminal. Ensure the serial port has been selected in the program and that the appropriate baud rate has been selected. Note that MVP•X are set to 19,200 baud at the factory.
- Connect the instrument to the computer using the data/power cable
- Unplug the data/power cable from the instrument to turn the instrument off.
- Hold down the < ENTER > key.
- Plug the data/power cable into the instrument to turn the instrument on.
- Release the <ENTER> key once the prompt '>' is displayed.

MVP•X will now accept command line input. See the Appendix for a list of advanced commands.

Returning MVP•X to Factory Default Settings for Use with Rolls-Royce MVPs

As MVP•X is set to ignore character input and output data on power up, it is necessary to interrupt the data flow. See "Interrupting the Monitor Command." Once that is complete, perform the following steps:

- Open a terminal emulation program such as HyperTerminal. Ensure an RS-485 serial port has been selected in the program. By default, MVP•X should be set to 19,200 baud. The terminal emulation program must be configured to the appropriate baud rate.
- Connect the instrument to the computer using a data/power cable. Using the terminal emulation program, issue the following commands to the instrument:
 - *SET S C* (set sample rate continuous at 25 Hz)
 - *SET DETECT 06* (set fixed BAUD rate of 19200)
 - *SET EMU BROOKE* (set P,SV,C and T output order)
 - *SET RX OFF* (disables reception of characters at next power up)
 - *SET STARTUP NOHEADER* (disables the power up header information)
 - *SET STARTUP MONITOR* (enables data output on power up)
 - *SET SCAN NOTIME* (removes time column from output)
 - *SET SCAN NODATE* (removes date column from output)
 - *SET SCAN NOSALINITY* (removes salinity column from output)
 - *SET SCAN NOBATT* (removes battery voltage from output)

Note: Details on the *SET DETECT* command can be found in the Appendix.

- Unplug the data/power cable from the instrument to turn the instrument off.
- Plug the data/power cable into the instrument to turn the instrument on.

Output Formats

Default Output Format

MVP•X are set to display pressure, sound velocity, conductivity, and temperature, in that order. If any of those sensors are not installed, no value is displayed for that sensor. Note that only the order of the **real** values is affected by this command. The following table shows the decimal format for each Xchange™ sensor:

Sensor	Units	Default Format
SV•Xchange™	m/s	1234.567
Conductivity•Xchange™	mS/cm	12.346
Pressure•Xchange™	dBar	1234.56
Temperature•Xchange™	C	12.345

Example CTD output:

```
0000.61 33.859 21.950
0000.65 33.860 21.950
0000.69 33.857 21.950
0000.65 33.859 21.950
0000.61 33.857 21.951
0000.59 33.858 21.951
0000.61 33.858 21.951
0000.59 33.859 21.951
0000.61 33.858 21.951
0000.59 33.860 21.951
0000.59 33.858 21.950
```

Example SVPT output:

```
0000.61 1431.859 21.950
0000.65 1431.860 21.950
0000.69 1431.857 21.950
0000.65 1431.859 21.950
0000.61 1431.857 21.951
0000.59 1431.858 21.951
0000.61 1431.858 21.951
0000.59 1431.859 21.951
0000.61 1431.858 21.951
0000.59 1431.860 21.951
0000.59 1431.858 21.950
```

Support

Troubleshooting

Instrument fails to communicate:

- Is the connector damaged?
- Check the cables
 - Is the data/power cable connected to the instrument and computer?
 - Are there any cuts in the cable?
 - If using a cable other than an AML cable, it should be configured as a null modem cable.
 - If using multiple cable lengths, the extensions should **not** be configured as null modem cables.
- If using external power over a long cable, check the voltage drop over the cable. Measure the voltage across a 10 watt, 27 Ω , resistor across pins 2 and 3 of the cable. The voltage must be above 8 volts.
- Are the communication settings in the program used on the computer correct?
 - Comm port selection
 - 8 bits
 - 1 stop bit
 - No parity
 - No hardware flow control
 - Baud rate between 600 and 38,400 baud
- Are the communication settings in the instrument correct?
 - Was the instrument specifically set to one baud rate last time? If so, use that baud rate to resume communications.
 - Was the instrument set to only RS-232 or only RS-485 last time? If so, resume communications in the required protocol.
 - Was the instrument set to RX OFF last time? If so, a carriage return must be sent to the instrument immediately after power is applied to interrupt this mode.
 - Was the instrument set to monitor on power up mode? If so, a carriage return must be sent to the instrument immediately after power is applied to interrupt this mode. To interrupt monitor on power up, hold down the ENTER key while applying power to the instrument.

Instrument generates noisy data:

- Is the connector damaged, dirty, or corroded?
- If connected to external power, is there noise on the power supply? Switch-mode power supplies are common sources of noise.
- Nearby EMI sources such as electric motors, generators, and transformers can create noise. If possible, move the instrument and its cables away from the noise source.
- Are the sensor/s clean?
- Are there bubbles on or in the sensor/s?
- Are the sensor/s damaged?

- Is there something nearby affecting the water temperature?

SeaCast fails to recognize a sensor:

- Be sure to download the latest version of SeaCast.

SV•Xchange data does not match CTD-calculated SV:

- Owing to the error associated with each individual sensor and Chen and Millero's equation¹, sound velocity calculated from CTD values will fall within approximately ± 0.4 m/s of the actual value 95% of the time. It is not uncommon to see differences of this size between directly measured sound velocity and CTD-calculated sound velocity.

¹ Chen-Tung Chen and Frank J. Millero, "Speed of sound in seawater at high pressures," *The Journal of the Acoustical Society of America* 62, no. 5 (1977): 1129-1135.

Contact AML Oceanographic

Service

To request an RMA or technical support

Email: service@AMLOceanographic.com

Phone: 1-250-656-0771

Phone : 1-800-663-8721 (NA)

Fax: 1-250-655-3655

Sales

For all general sales inquiries

Email: sales@AMLOceanographic.com

Phone: 1-250-656-0771

Phone : 1-800-663-8721 (NA)

Fax: 1-250-655-3655

Website

<http://www.AMLOceanographic.com>

Customer Portal

My AML Oceanographic is AML's online data centre. This secure area within our website is designed to offer one easy location for interested individuals and organizations - distributors, customers, prospects, and other members of our community - to manage their interactions with AML. *My AML Oceanographic* will allow you to:

- View and manage your assets (instruments and sensors)
- Consult instrument diagnostic summaries
- View and download calibration and conformity certificates
- View and manage your technical support cases
- Consult and download sales estimates, sales orders, and invoice copies
- View account balances and generate account statements
- Assess inventory availability at AML

To access the Customer Portal, please navigate to the *Support* button - located on the top right of the AML Oceanographic home page - select *Customer Centre* from the options on the drop down menu and follow the instructions provided.

Mailing and Shipping Address

AML Oceanographic
2071 Malaview Ave.
Sidney, BC, Canada
V8L 5X6

Appendices

Commands

When using SeaCast, the full command set is not usually necessary. However, text commands are available. Below is a listing of commonly used commands. Note that some commands are only available on instruments equipped with the applicable Xchange™ sensors.

Communications Commands

Command	Description	Requires
SET FORCE 232	Sets com mode to RS-232. Power must be cycled for changes to take effect.	
SET FORCE 485	Sets com mode to RS-485. Power must be cycled for changes to take effect.	
SET FORCE AUTO	Sets for auto-detection of RS-232 or RS-485 comms. Note that if instrument is not connected to a com port on power up, it assumes RS-485 operation & will remain in that mode until powered down.	
DISPLAY FORCE	Displays current com mode (ie RS232, RS485, AUTO)	
DISPLAY DETECT	Displays the baud rate detection settings.	
SET DETECT a b	Sets the baud rate detection. "a" sets the number of autobaud detection attempts before the instrument reverts to the default baud rate set by "b". Setting 'a'=0 forces the instrument to a fixed baud rate determined by "b." "b"= 1 = 600 baud 4 = 4800 baud 7 = 38400 baud 2 = 1200 baud 5 = 9600 baud 8 = 57600 baud 3 = 2400 baud 6 = 19200 baud 9 = 115200 baud	

Sampling Rate Commands

Command	Description	Requires
DISPLAY SAMPLE RATE	Displays the time-based sampling rate	
SET SAMPLE n t	Sets the desired sampling rate. "n" is a number and "t" is the time units. Using the slash (/) character should be read as "per." For instance, 5 s means sampling happens every 5 seconds. 5/s means 5 samples per second. Examples are: SET S C sets the sampling to continuous (25 Hz) SET S 5 /s 5 samples per sec SET S 1 s Sample 1 time every 1 second SET S 2 /m 2 samples per minute SET S 5 m Sample 1 time every 5 minutes SET S 2 /h 2 samples per hour SET S 24 h Sample 1 time every 24 hours	

Output Format Commands

Command	Description	Requires
DISPLAY SCAN	Displays current scan options.	
SET SCAN NODENSITY	Turns the calculated density channel off.	C•X, T•X, and P•X or SV•X, T•X, and P•X
SET SCAN DENSITY	Turns the calculated density channel on.	C•X, T•X, and P•X or SV•X, T•X, and P•X
SET SCAN NOSALINITY	Turns the calculated salinity channel off.	C•X, T•X, and P•X or SV•X, T•X, and P•X
SET SCAN SALINITY	Turns the calculated salinity channel on.	C•X, T•X, and P•X or SV•X, T•X, and P•X
SET SCAN NOSV	Turns the calculated sound velocity channel off, removing it from the instrument output scans. Current salinity display status is viewable using DISPLAY SCAN.	C•X, T•X, and P•X
SET SCAN SV	Turns the calculated sound velocity channel on, allowing it to be present in instrument output scans. Current salinity display status is viewable using DISPLAY SCAN. This is only available when C,P, and T sensors are attached.	C•X, T•X, and P•X
SET SCAN TIME	Enables displaying time in data scan.	
SET SCAN NOTIME	Disables time from being displayed in data scan.	
DISPLAY STARTUP	Displays the power up output settings.	
SET STARTUP PROMPT	Sets the instrument to wait for user commands on power up.	
SET STARTUP SCAN	Sets the instrument to output one scan on power up, and then wait for a user command.	
SET STARTUP MONITOR	Sets the instrument to start monitoring data on power up.	
SET STARTUP NOHEADER	Disables the instrument identification header output on power up.	
SET STARTUP HEADER	Enables the instrument identification header output on power up.	

General Commands

Command	Description	Requires
SCAN	Measures and outputs one scan of data.	
MONITOR	Scans at the set sampling rate.	
VERSION	Displays the instrument identification header.	
DISPLAY OPTIONS	Displays the instrument status and user settings.	
ZERO	Corrects the barometric offset to set zero pressure at surface for current barometric pressure.	P•X
ZERO OFF	Disables barometric offset.	P•X
DIS TIME	Displays current time. Time format is hh:mm:ss.ss	
SET TIME hh:mm:ss.ss	Sets instrument time using 24 hour clock in format hh:mm:ss.ss	
DETECT	Checks each slot in logger board to identify what is plugged in and displays sensor / board type and serial number or "empty" for each slot.	
TALK n	Enables communications directly with a sensor board via the logger board, where n = value from 1-3 that identifies the slot number of the board to be communicated with. See <i>DETECT</i> command.	
CTRL+C	Press CTRL key and C key at same time to exit sensor board talk mode and return to logger communications.	

Technical Specifications

Sensors

Primary Xchange™ Sensors					
Type	Range	Accuracy	Precision	Resolution	Response Time
Conductivity•Xchange™	0 to 2 mS/cm	0.01 mS/cm	0.003 mS/cm	0.001 mS/cm	25 ms at 1 m/s flow rate
Conductivity•Xchange™	0 to 70 mS/cm	0.01 mS/cm	0.003 mS/cm	0.001 mS/cm	25 ms at 1 m/s flow rate
Conductivity•Xchange™	0 to 90 mS/cm	0.01 mS/cm	0.003 mS/cm	0.001 mS/cm	25 ms at 1 m/s flow
SV•Xchange™	1375 to 1625 m/s	0.025 m/s	0.006 m/s	0.001 m/s	47 μs

Secondary Xchange™ Sensors					
Type	Range	Accuracy	Precision	Resolution	Response Time
Temperature•Xchange™	-2°C to 32°C	0.005°C	0.003°C	0.001°C	100 ms
Temperature•Xchange™	-5°C to 45°C	0.005°C	0.003°C	0.001°C	100 ms
Temperature•Xchange™	0°C to 65°C	0.005°C	0.003°C	0.001°C	100 ms
Pressure•Xchange™	50, 100, 200, 500, 1000, 2000, 4000, 5000, 6000 dBar	0.05%FS	0.03%FS	0.02%FS	10 ms

Calculated Parameters				
Type	Required Sensors	Equation	Accuracy	Range
Salinity	C•X, T•X, P•X	TEOS10	±0.010 psu	0 to 42 psu
Salinity (from SV)	SV•X, T•X, P•X	AML '07	±0.035 ppt	0 to 42 ppt

Density	C•X, T•X, P•X	TEOS10	±0.027 kg/m ³	990 to 1230 kg/m ³
Density (from SV)	SV•X, T•X, P•X	TEOS10	±0.051 kg/m ³	990 to 1230 kg/m ³
SV (from CTD)	C•X, T•X, P•X	Chen & Millero '77 ²	0.5 m/s	---

Electrical

- Mother Board
 - Two dedicated slots
 - Primary Xchange™ sensor slot
 - Secondary Xchange™ sensor slot
- Sensor Boards
 - Sound Velocity or Conductivity Xchange™ sensor board
 - Pressure or Temperature Xchange™ sensor board
- RS-485 (½ duplex ASCII)
- Fixed to 19200 Baud

Power

- External Power Supply: 8 to 26 VDC

Current Draw at 12VDC			
Primary Sensor	Secondary Sensor	Secondary Sensor	Current Draw (mA)
			119
C•X	-	-	122
C•X	P•X	-	129
C•X	T•X	-	138
C•X	P•X	T•X	145
SV•X	-	-	120
SV•X	P•X	-	127
SV•X	T•X	-	135
SV•X	P•X	T•X	145
-	T•X	-	135
-	P•X	-	127

Pressure Case

- Environmental Limits
 - Storage: -40°C to 60°C
 - Usage: -20°C to 45°C

² Chen and Millero, "Speed of sound in seawater at high pressures," 1129-1135.

Housing						
Status	Type	Depth Rating	Diameter	Length	Weight (in water)	Weight (in air)
Standard	Titanium	6000 m	5.0 cm	22.4 cm	1.1 kg (2.5 lbs)	1.6 kg (3.6 lbs)

Connectors					
Type	Status	Pins	Sex	Material	Manufacturer
Bulkhead	On titanium housings	Micro 6	Female	Titanium	Subconn

Sampling Capabilities

- Frequency
 - Time: From 25 samples per second to 1 sample per hour
- Configuration
 - Single scan or continuous output
 - On command or data on power up

Included Items

- MVP-X instrument
- One primary sensor blanking plug
- Two secondary sensor blanking plugs
- USB stick with manuals and documentation

Ordering Codes

Instrument Packages (sensors included)

PKG-MVPX-CTD-05	MVP•X, 500 dBar, CTD Configuration
PKG-MVPX-CTD-10	MVP•X, 1000 dBar, CTD Configuration
PKG-MVPX-CTD-40	MVP•X, 4000 dBar, CTD Configuration
PKG-MVPX-CTD-60	MVP•X, 6000 dBar, CTD Configuration
PKG-MVPX-SVPT-05	MVP•X, 500 dBar, SVPT Configuration
PKG-MVPX-SVPT-10	MVP•X, 1000 dBar, SVPT Configuration
PKG-MVPX-SVPT-40	MVP•X, 4000 dBar, SVPT Configuration
PKG-MVPX-SVPT-60	MVP•X, 6000 dBar, SVPT Configuration

Instruments (sensors not included)

PDC-MVPX-CTD-05	MVP•X, 500 dBar, CTD Configuration
PDC-MVPX-CTD-10	MVP•X, 1000 dBar, CTD Configuration
PDC-MVPX-CTD-40	MVP•X, 4000 dBar, CTD Configuration
PDC-MVPX-CTD-60	MVP•X, 6000 dBar, CTD Configuration
PDC-MVPX-SVPT-05	MVP•X, 500 dBar, SVPT Configuration
PDC-MVPX-SVPT-10	MVP•X, 1000 dBar, SVPT Configuration
PDC-MVPX-SVPT-40	MVP•X, 4000 dBar, SVPT Configuration
PDC-MVPX-SVPT-60	MVP•X, 6000 dBar, SVPT Configuration

Sensors

XCH-SV-STD	SV•Xchange™ (1375-1625m/s) Range *Replaces XCH-0002*
XCH-SV-1120	SV•Xchange™ (1100-2000m/s) Range
XCH-SV-0520	SV•Xchange™ (500-2000m/s) Range
XCH-CND-RA002	C•Xchange™ Right Angle, Ultra Freshwater (0-2mS/cm) Range
XCH-CND-RA070	C•Xchange™ Right Angle, Oceanographic (0-70mS/cm) Range
XCH-CND-RA090	C•Xchange™ Right Angle, Oceanographic (0-90mS/cm) Range
XCH-CND-ST002	C•Xchange™ Straight, Oceanographic (0-70mS/cm) Range
XCH-CND-ST070	C•Xchange™ Straight, Ultra Freshwater (0-2mS/cm) Range
XCH-TMP-n232	T•Xchange™ (-2 to 32 C) Range
XCH-TMP-n545	T•Xchange™ (-5 to 45 C) Range
XCH-TMP-065	T•Xchange™ (0 to 65 C) Range
XCH-PRS-0050	P•Xchange™ 50 dBar
XCH-PRS-0100	P•Xchange™ 100 dBar
XCH-PRS-0200	P•Xchange™ 200 dBar
XCH-PRS-0500	P•Xchange™ 500 dBar
XCH-PRS-1000	P•Xchange™ 1000 dBar

XCH-PRS-2000	P•Xchange™ 2000 dBar
XCH-PRS-4000	P•Xchange™ 4000 dBar
XCH-PRS-5000	P•Xchange™ 5000 dBar
XCH-PRS-6000	P•Xchange™ 6000 dBar
XCH-PRS-6000-T065	P•Xchange™ 6000 dBar, Extended temperature calibration from 0-65 C

Warranty

AML Oceanographic warrants the instrument for a period of two years from the date of delivery. AML will repair or replace, at its option and at no charge, components which are found to be defective. The warranty applies only to the original purchaser of the instruments. The warranty does not apply if the instrument has been damaged, by accident or misuse, and is void if repairs or modifications are made by any other than authorized personnel.

This warranty is the only warranty given by AML. No warranties implied by law, including but not limited to the implied warranties of merchantability and fitness for a particular purpose shall apply. In no event will AML be liable for any direct, indirect, consequential, or incidental damages resulting from any defects or failure of performance of any instrument supplied by AML.

Technical Overview Drawings

THE INFORMATION CONTAINED IN THIS DRAWING IS THE SOLE PROPERTY OF AML OCEANOGRAPHIC LTD.
 ANY REPRODUCTION IN PART OR WHOLE WITHOUT THE WRITTEN PERMISSION OF AML OCEANOGRAPHIC LTD IS PROHIBITED

REVISION TABLE

REV	DESCRIPTION	BY	DATE

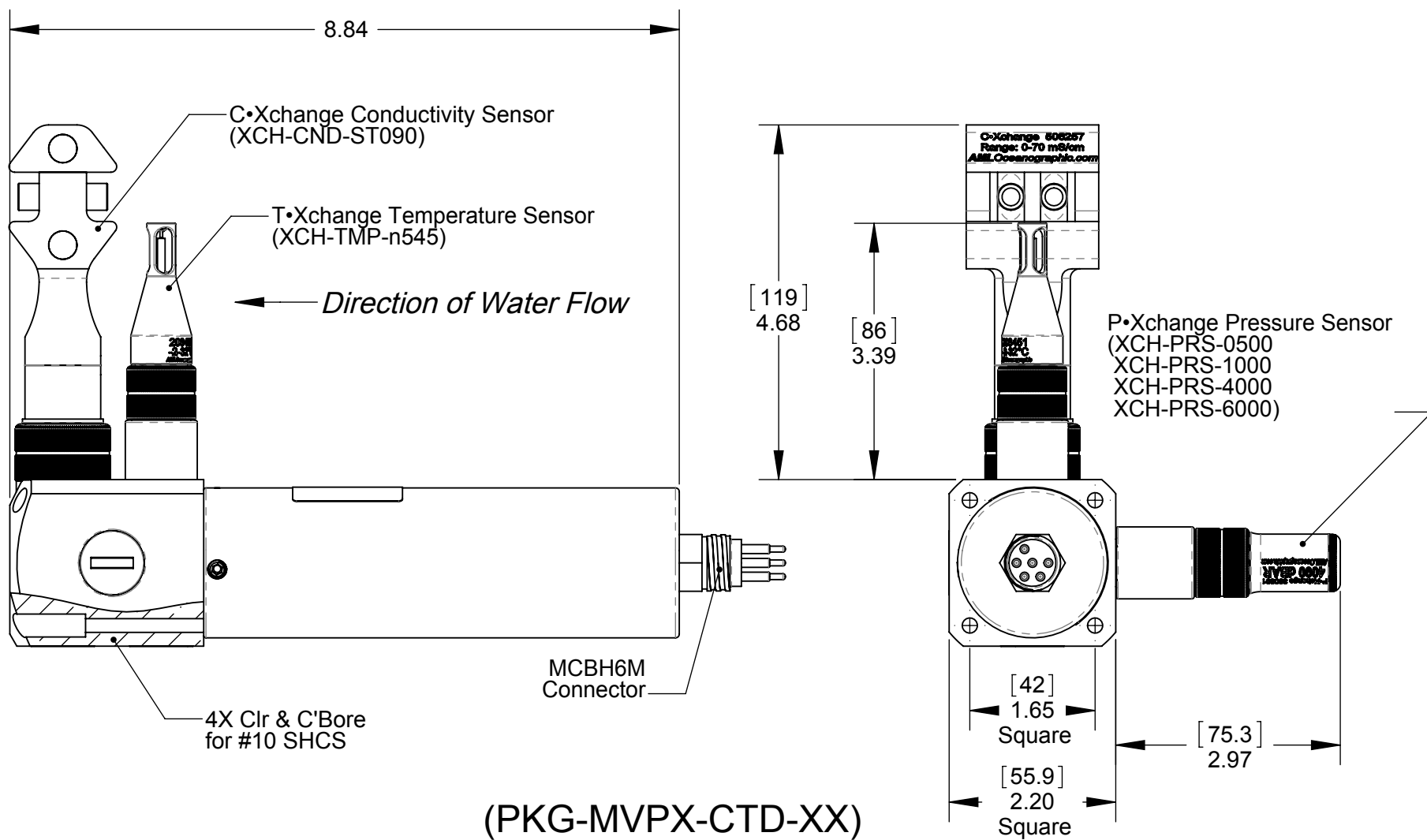

(PKG-MVPX-CTD-XX)

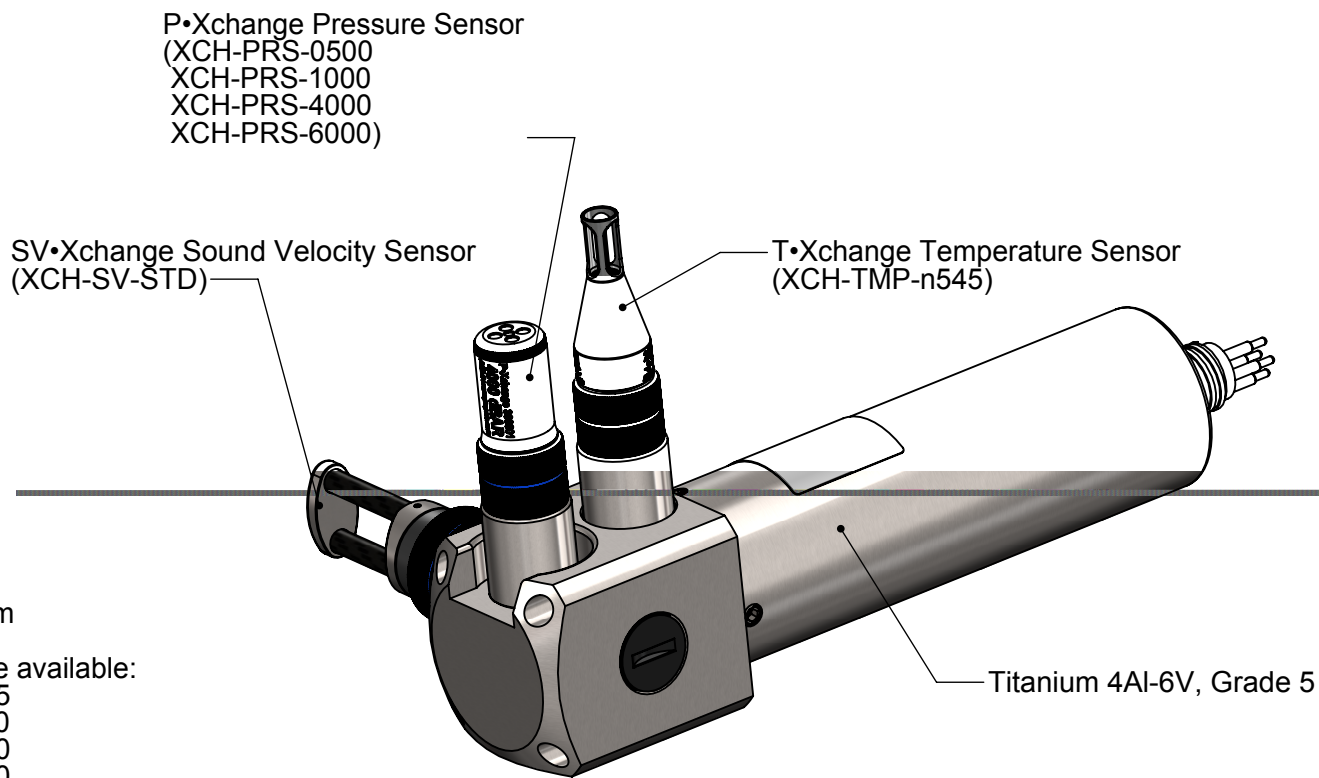

(PKG-MVPX-SVTP-XX)

NOTES:

1. Depth Rating: up to 6000m
2. Weight: TBD
3. A number of packages are available:
 - PKG-MVPX-CTD-05
 - PKG-MVPX-CTD-10
 - PKG-MVPX-CTD-40
 - PKG-MVPX-CTD-60
 - PKG-MVPX-SVTP-05
 - PKG-MVPX-SVTP-10
 - PKG-MVPX-SVTP-40
 - PKG-MVPX-SVTP-60



2071 Malaview Avenue W., Sidney B.C. Canada V8L 5X6 (250) 656 0771 Fax: (250) 655 3655

TOLERANCES:
 ANGLES: ± 1°
 FRACTIONS: ± 1/32
 HOLE SIZES: ± 0.005(0.13)
 0.00: ± 0.015(0.38)
 0.000: ± 0.005(0.13)

UNLESS OTHERWISE SPECIFIED:
 ORIGINAL SCALE: 1:2
 DIM'S ARE IN INCHES (MM)
 SURFACE FINISH: 63

TITLE: MVP X - Technical Overview			
DRAWN DO	DRAWING NO.: MC3-GA-03888	REV	AML NO. PDC-MVPX-XXXX-XX
DATE 11SEP2014	MATERIAL: N/A		SHEET NO.
3rd ANGLE PROJECTION	SIZE B	SLD FILE NO.: MC3-MA-03884	Sheet 1 of 2

Pin

1	White	D(-)
2	Black	Power Gnd
3	Red	+12 Volts
4	Green	D(+)
5	Blue	N/C
6	Brown	N/C

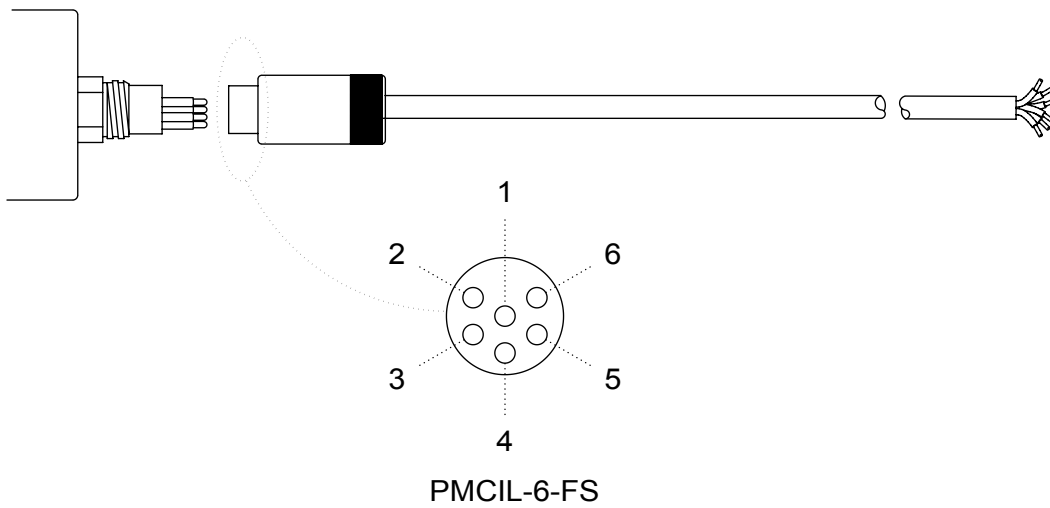

2071 MALAVIEW AVE. W., SIDNEY, B.C. CANADA V8L 5X6
PH:(250) 656 0771 FAX: (250) 655 3655
www.AMLoceanographic.com

TITLE

PMCIL-6-FS TO RS-485
INTERFACE DIAGRAM

SYSTEM
MC3

AML PART NO.
PDC-MVPX-XXXX-XX

DATE
11SEP2014

SLDRW NO.
MC3-GA-03888